

Fermator

AUTOMATIC DOORS FOR LIFTS

ASSEMBLING INSTRUCTIONS AND REGULATION OF CABIN DOORS



PARTS DESCRIPTION	3
SITUATION OF THE OPERATOR IN THE CABIN	3
ADJUSTMENT OF CLEAR OPENING IN CENTRE PARTING DOORS	4
ADJUSTMENT OF CLEAR OPENING IN SIDE OPENING DOORS	4
INSTALLATION OF GUIDE SHOES AND HANGERS	5
ADJUSTMENT OF PANELS	5
ADJUSTMENT OF WHEELS	6
LANDING DOOR COUPLING	6
CORRECT ADJUSTMENT BETWEEN CLAMP AND RETAINER	7
ELEMENTS SITUATION	7
CDL-S LOOKING DEVICE	8
VWF-4+ MODULE	
PROGRAMMING.....	10
INPUTS	11
PROGRAMMING EXAMPLES	14
CHARACTERISTICS PAGE	15
EMERGENCY SUPPLIER	17
OPERATION	18
INSTALATION.....	18
STATUS LEDS	19
BATTERY CONTROL.....	19
SCHEME.....	19
DECLARATION OF CONFORMITY	20

Central Cabin Door

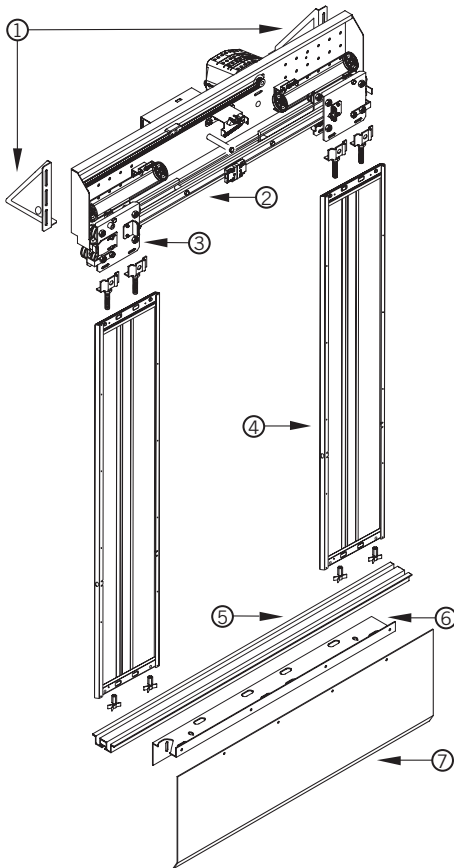

- 1 - Fixation bracket
- 2 - Operator
- 3 - Plate
- 4 - Panels
- 5 - Tread
- 6 - Tread support
- 7 - Toe guard

Side Cabin Door

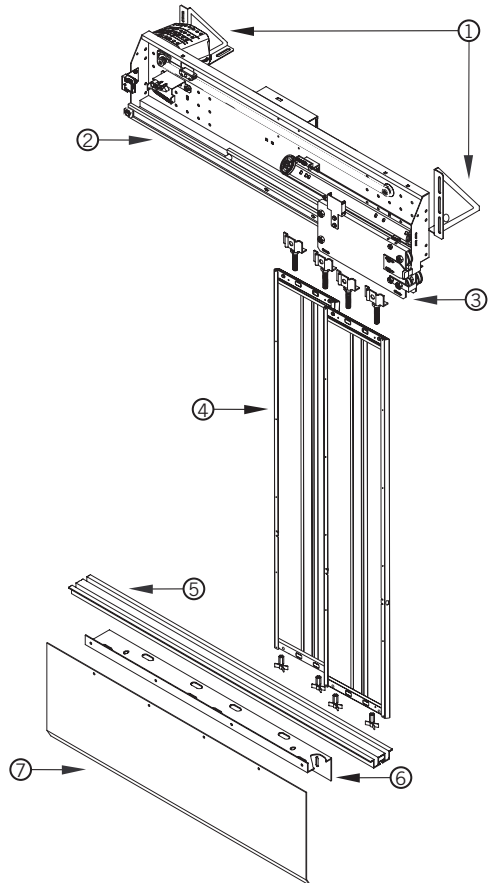

- 1° Place the brackets in the guide tracks situated in the cabin roof.
- 2° Place the operator 220mm. higher than the clear height of the cabin (fig. 1).
- 3° Tighten the operator to the brackets (fig. 2).
- 4° Let 30mm. between the front part of the cabin and the outside of the operator regulated with the brackets (fig. 3).
- 5° Fix the brackets in the guide tracks.

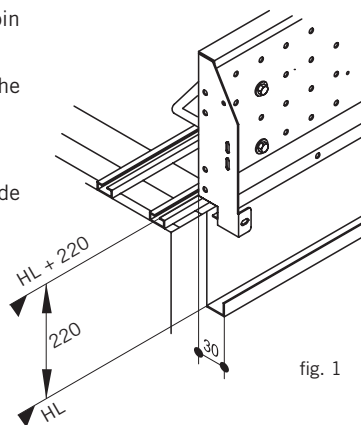

fig. 1

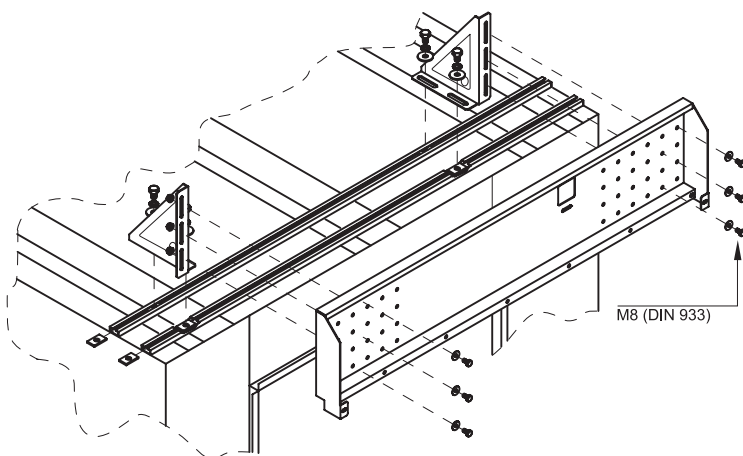

fig. 2

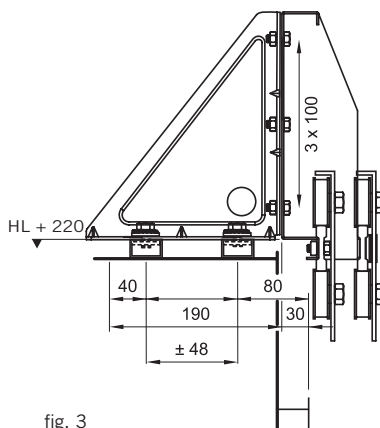

fig. 3

Slow plates:

- 1° Place the slow plates at the operator extremes.
- 2° Check that distance between them is X^* .
- 3° Tighten the air cord clamps (fig. 2).

Fast plates:

- 1° Place the fast plates in flush position with the slow plates.
- 2° Tighten the air cord clamps (fig. 2).

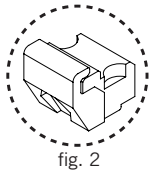

fig. 2

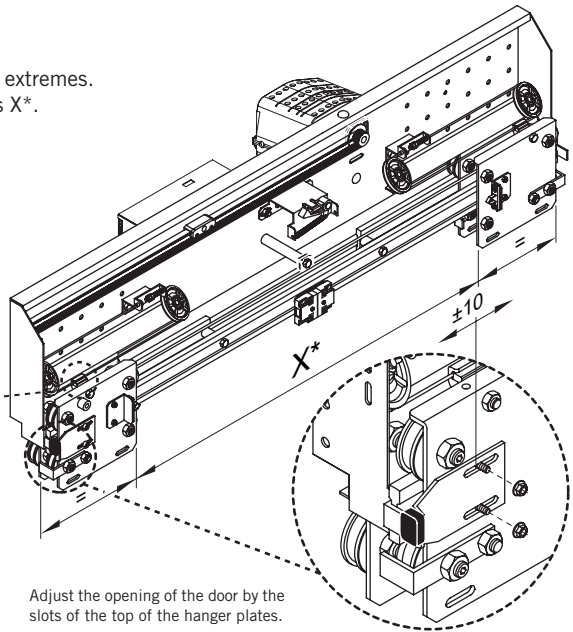

fig. 1

* X = Distance between plates when the door is closed + CO + 15mm. (formula for operators with automatic landing doors).

Adjust the opening of the door by the slots of the top of the hanger plates.

* X = Distance between plates when the door is closed + CO (formula for semiautomatic landing doors).

ADJUSTMENT OF CO. IN SIDE OPENING DOORS

- 1° Place the flush plates in open position.
- 2° Check that between the extreme plate and the end of opening there is a distance of CO + 15mm., as shown fig. 1. Use the slots of the top plate for adjusting the door (see figure 1).
- 3° Once the fast plate is in the flush position with the slow plate, fix the synchronization cord (fig. 2).

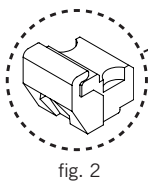

fig. 2

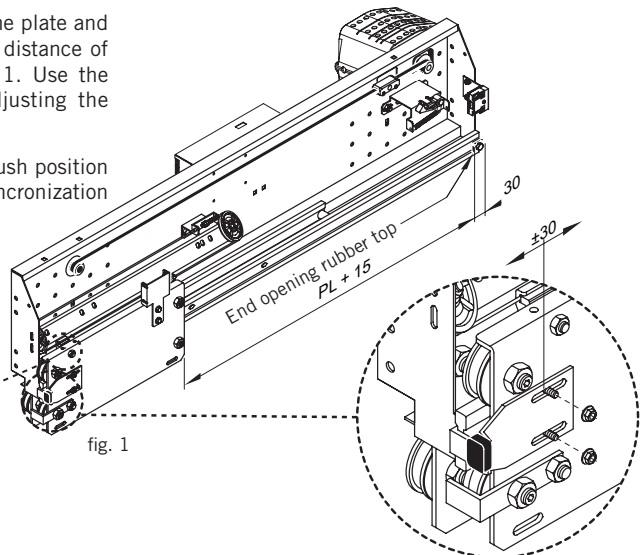
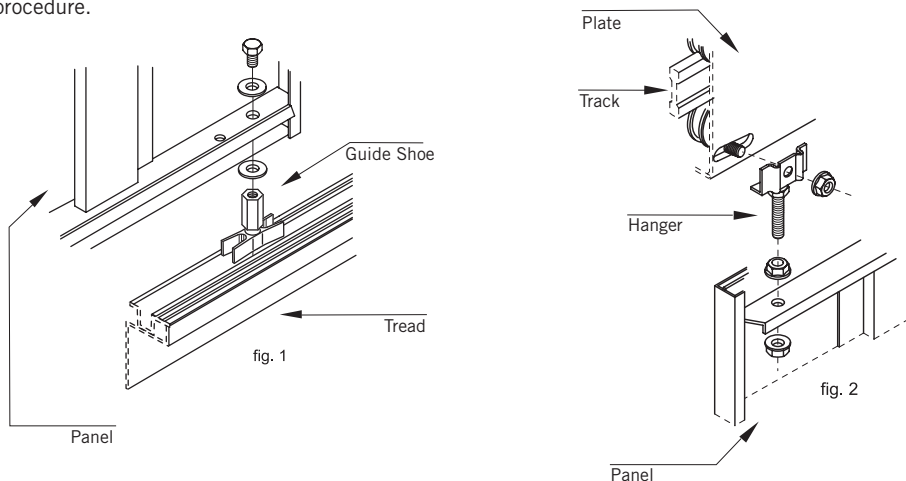

fig. 1

Guide shoes (fig. 1) and hangers (fig. 2) installation in panel procedure.



ADJUSTMENT OF PANELS

The following procedure is the same for any type of cabin door (Central or side opening).

- 1° Once the panels are placed into their corresponding plates, slide them through the side they open till they are raised with the frames.
- 2° Tighen the nuts that hold the plates with the hangers (fig. 1).
- 3° Straighthen the panels with the help of the hanger nuts until the panel is parallel to the post (fig. 1) Check that between tread, between panel and panel, and between panel and post it exist a distance of 5mm. (fig. 2).

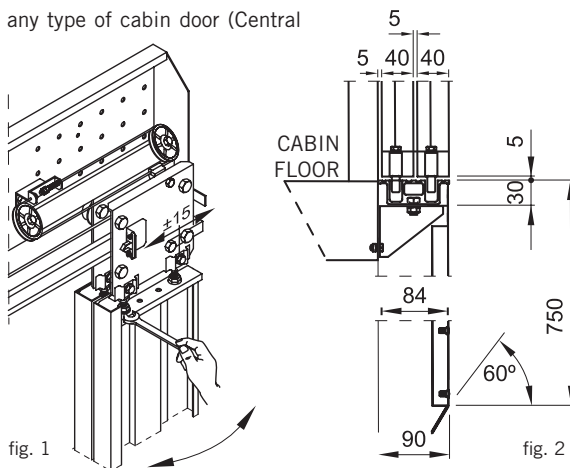

Alignment of panels:

The panels should slide smoothly in the tread. If for any reason the panels do not slide smoothly, follow these instructions:

- 1° Disassemble the inferior guides.
- 2° Straighthen the panels to remain parallel to the tread.
- 3° Assemble the guides.

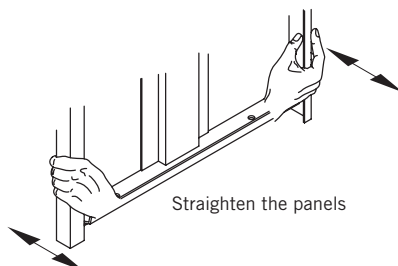
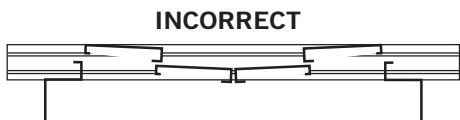

- 1° The adjustment will be made by the inferior wheels (eccentric), rotating the shaft we can adjust the force done to the track.
- 2° This adjustment may be done with an allen wrench of 5 mm. and the flat key. An excessive tightening could stop the panel.

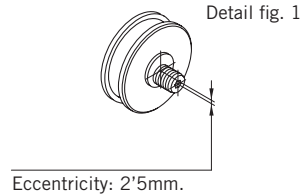
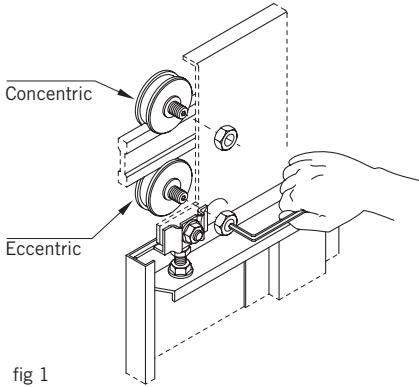

! Wheels are adjusted in factory, only should be regulated in case of bad functioning.

LANDING DOOR COUPLING

The cabin door includes the moving skate that does the opening of the landing door.

When the cabin door is closed, the moving skate remains closed, so that while the cabin is moving it does not work with the landing locks (fig.1).

Before the opening manoeuvre, the moving skate opens and unlocks the landing lock so that it can start the opening and closing of the landing door.

In the closing cycle, the movements will be other way round, moving the skate while closing, and closing the skate to free the landing lock, so that the landing door will be ready to close and the cabin free to move.

The correct position of the skate is centred in relation with the rollers of the landing lock.

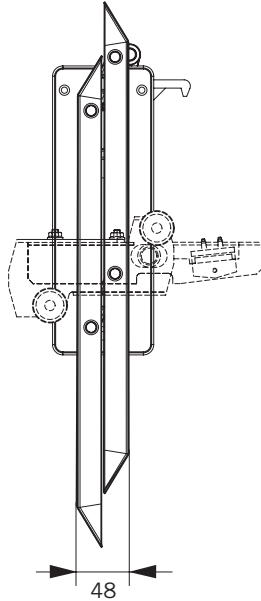

Close Position
fig. 1

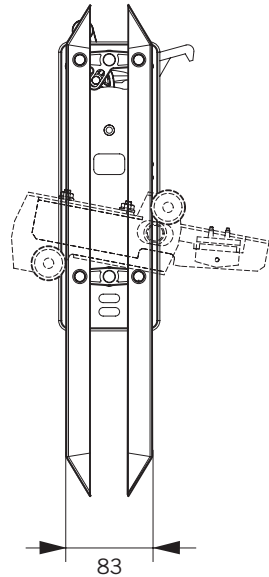

Open Position
fig. 2

Once the skate is placed (145mm. between the end of the plate and the shaft of the skate), in locked position, adjust the clamp-retainer set by the slots (8 x 25) of the support with a gap of 0'5 mm. in the horizontal and vertical shaft.

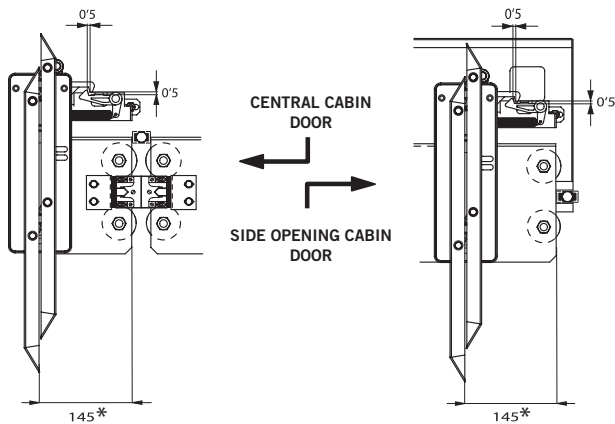

* Doors 4 panels between CO 600 until CO 915 the measure is 100mm.

ELEMENTS SITUATION

- A- Distance between landing tread line and external part of the dragging wheels.
- B- Distance between cabin tread line and skate arms.
- C- Overlap between skate arms and dragging wheels.
- D- Distance between treads.

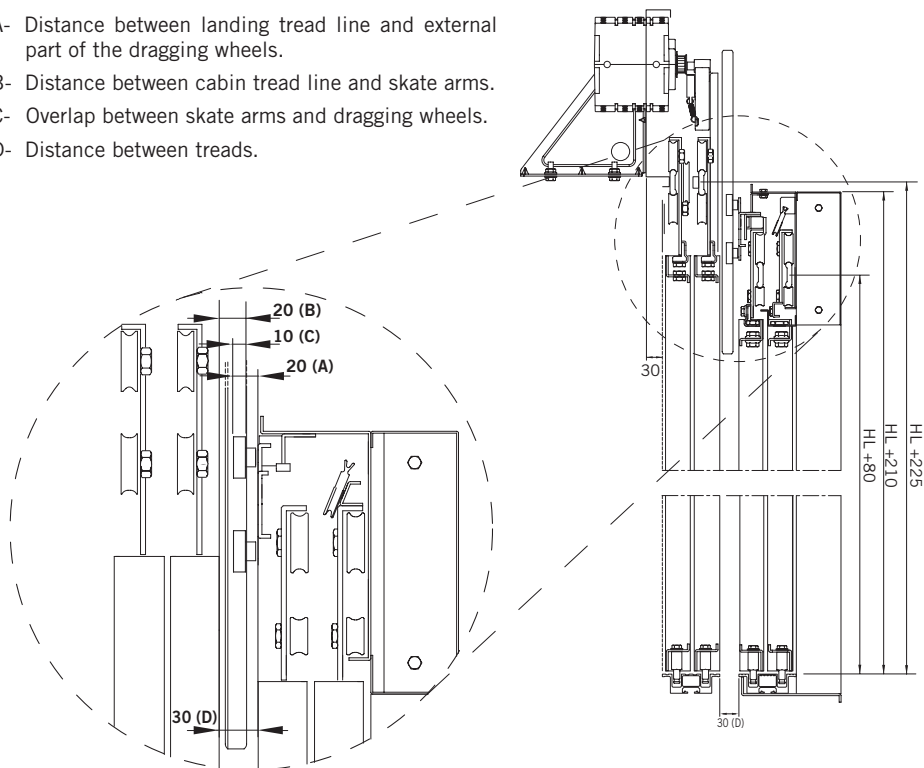

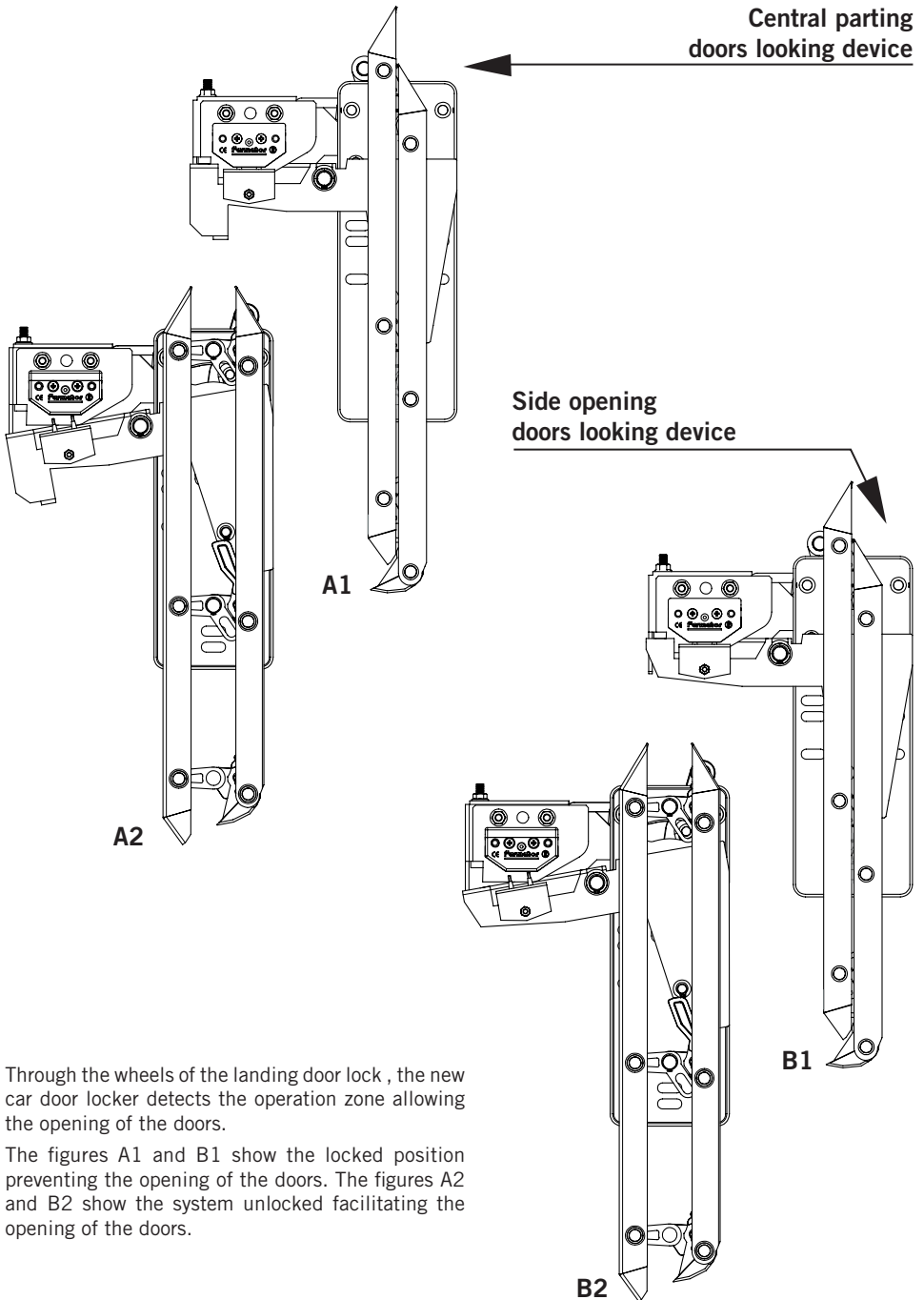

Through the wheels of the landing door lock , the new car door locker detects the operation zone allowing the opening of the doors.

The figures A1 and B1 show the locked position preventing the opening of the doors. The figures A2 and B2 show the system unlocked facilitating the opening of the doors.

TECHNICAL MANUAL AND ELECTRICAL MODULE REGULATION VVVF-4+

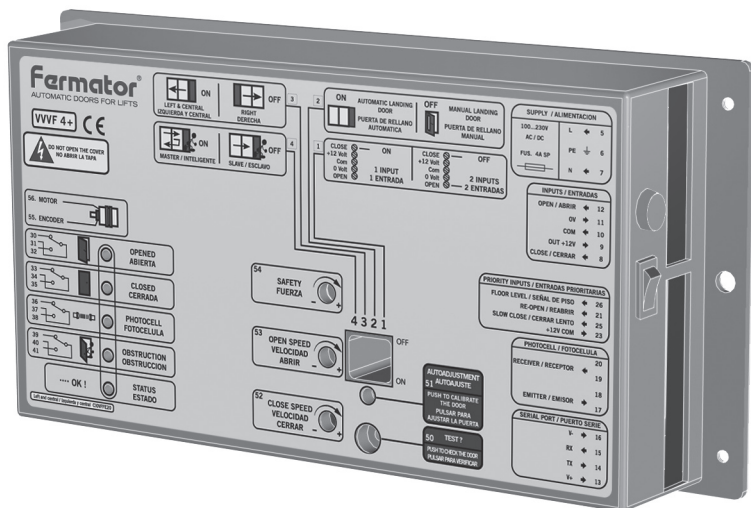

DESCRIPTION OF SWITCHES

The unit may be programmed using the DIL switches on the front of the unit. If any change is made to any of the above switch selections, the Mains Supply to the VVF-4+ unit **MUST** be switched OFF and ON again to read the new programming. The switches functions are:

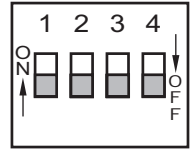

• **1.- 1 & 2 Inputs.**

ON: 1 Input.

The door control unit will be controlled by a single input. Any voltage between 12 to 250 volts AC or DC applied between terminals 8 & 10 will close the doors. Without input active the door opens. Open input is not used.

OFF: 2 Inputs.

The door control module will be controlled by two independent inputs. Any voltage between 12 to 250 volts AC or DC applied between terminals 8 & 10 will cause the doors to close. And between terminals 12 & 10 will cause the doors to open. In the absence of a signal, the doors will remain static. If both inputs are applied then the open signal has priority.

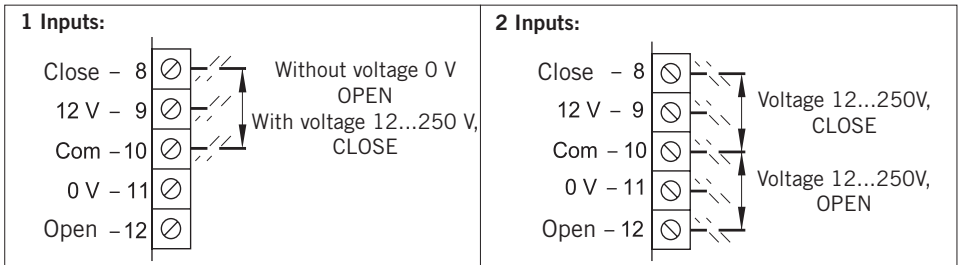

• **2.- Automatic / Semiautomatic.**

ON: Automatic.

Operators with skate (automatic landing). In this case a special movement is made for locking and unlocking the skate

OFF: Semiautomatic.

Operators without skate (Semiautomatic landing door).

• **3.- Rotation sense.**

ON: The control unit is expecting to control left hand or centre opening doors.

OFF: The control unit is expecting to control right hand opening doors. The sense is defined from the outside of the car, referring to the direction taken when the door is opening.

• **4.- Master and Slave.**

ON: Master.

The door control unit will execute instructions directly. Example: operation of the Photoelectric Detector will cause the doors to re-open immediately under control of the door control unit.

OFF: Slave.

There is no automatic reopen movements. The doors will only react to instruction given by the main lift controller by the inputs. Example: operation of the Safety Edge Detector will cause the door operato module to give a signal to the main lift controller via the PHOTOCCELL (36, 37, 38) output. The main lift controller then must remove the close signal and put the open signal.

POWER INPUTS 220-250 VOLTS SINGLE PHASE AC (5, 6, 7)

The circuit has been designed to operate on a mains supply of 230 Volts AC (+10%, -15%, 50 or 60 Hz). The unit will consume approx 1 Amp from the supply.

It is important that the Door Operator Module has a GOOD EARTH CONNECTION.

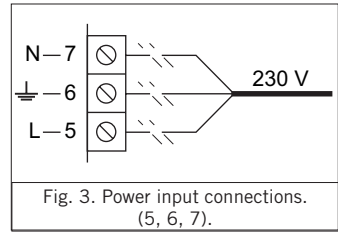
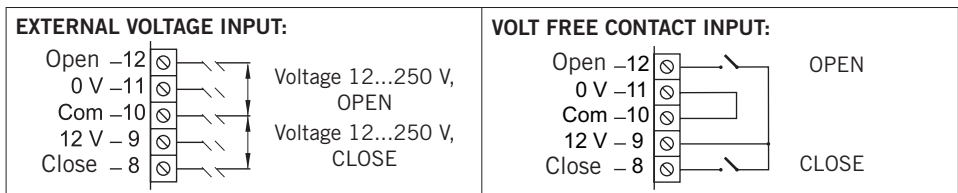

Fig. 3. Power input connections. (5, 6, 7).

CONTROL INPUTS (8, 9, 10, 11, 12)

The circuit can work with external voltage inputs or by means a volt free contact input.



- **12.- Opening Signal.**
Is a signal that orders the door to open. The tension to apply could be from 12 to 250 V., with an external supply between this input and common. (10)
- **11.- 0 Volts.**
Is the opposite pole to 12V, in the case of using internal tension should be connected by a common input.
- **10.- Common.**
Is the reference used for the two inputs.
- **9.- 12 Volt.**
Isolated 12 Volts output available to control the door via a volt free contact.
Features are:
 - a) This supply must only be used for this purpose.
 - b) This contact must be isolated from any other power supply.
- **8.- Close signal.**
This signal is used for ordering to close the door.

SERIAL PORT (13, 14, 15, 16)

The serial port is used to connect with external devices like the diagnostic console, interfaces and future expansion devices. Operating speed 1.200 Baud, current loop.

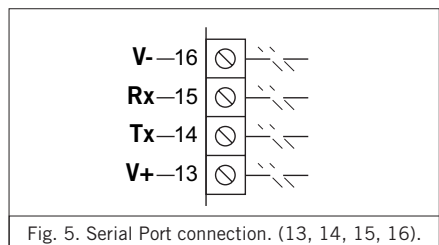

Fig. 5. Serial Port connection. (13, 14, 15, 16).

PHOTOCELL (17, 18, 19, 20)

One of the most relevant characteristics of this control is the optional incorporation of a photocell. It is composed by a emitter and receptor infrared.

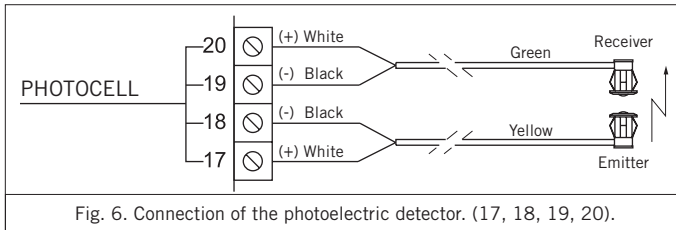

Fig. 6. Connection of the photoelectric detector. (17, 18, 19, 20).

OTHER INPUTS (26, 21, 25, 23)

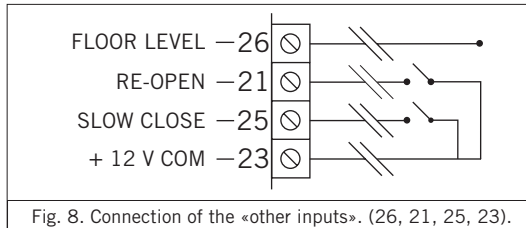

Fig. 8. Connection of the «other inputs». (26, 21, 25, 23).

- **26. Landing signal.**
This input is for connecting the external emergency current supplier that allows the opening manoeuvre in the case of power failure by a battery of 12V, able to give power during 15 seconds for a passengers rescue.
- **21. Reopening.**
This signal is for installing the cabin door switch or an external barrier. This signal has priority to the closing signal. Use contacts free on tension. For activating close one contact with the main supply +12V. (23).
- **25. Slow Closing.**
This input orders to the operator to close the door slowly regardless of the barrier and control signs. Is created for working with detection of fire centres.
- **23. + 12 V. COM**
This terminal is used for giving with an isolated contact a reopening order or a slow closing.
Always use contacts free of tension and usually open.

OUTPUT RELAYS AND LED INDICATORS (from 30 to 41)

Output relays have been provided to give continuous information to the main lift controller concerning the status of the doors. One 2 Amp 150 Volts volt free change over contact is provided on each relay that may be used by the main lift controller to pilot such information as «doors fully opened», «doors fully closed», «Photoelectric detection», «obstruction in the doorway» and «door control O.K.».

- **Opened.**

Led indicator and relay activated when the doors are fully open.

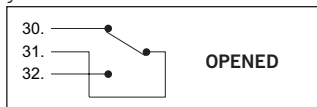

- **Closed.**

Led indicator and relay activated when the doors are fully closed and locked.

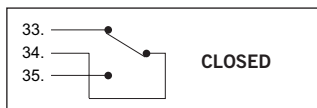

- **Photocell.**

Led indicator and relay activated when the photocell or the reopening input is operated.

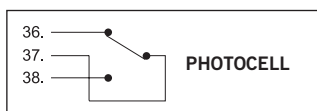

- **Obstruction.**

Led indicator and relay activated when an obstacle is detected that stops the doors from closing. The signal will reset when the doors reach the opened or closed position.

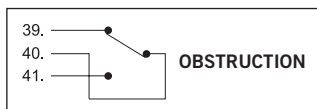

- **Status.**

Blinking led indicating proper working conditions.

TEST PUSHBUTTON (50)

Operation of the Test pushbutton will cause a door open or close cycle.

AUTOADJUSTMENT PUSHBUTTON (51)

The Autoadjustment pushbutton is used to set up the doors. The doors will do 3 complete movements at fi rst the doors will close completely, then the doors will open slowly counting the pulses from the encoder built into the drive motor until they reach the open mechanical stop, and after a short delay the doors will close. From the information gained the microprocessor will calculate the acceleration and deceleration ramps and the bracking torque required to give the optimum control of the doors. Once the autoadjustment has been completed the parameter are stored in non- volatile EEPROM and will be used to calculate the optimum performance. The doors will open slowly for the fi rst operation after power has been removed from the door control unit. Autoadjustment only needs to be used when setting the initial parameters or when changes such as connecting or removing the Fermator Safety Detector are made.

CLOSE SPEED (52)

The door closing speed can be independently adjusted from 150 mm/s upto 600 mm/s.

OPEN SPEED (53)

The door opening speed can be independently adjusted from 200 mm/s upto 1.000 mm/s.

SAFETY (54)

This potentiometer is used to set the closing pressure onto an obstacle in the doorway. The closing pressure can be set between 40 and 150 Nw.

ENCODER (55)

An integral quadrature pulse encoder is connected to this input. The purpose of the encoder, which is situated inside the motor, is to inform the control of the exact position and speed of doors.

MOTOR (56)

Output to the 3 phase motor varying the voltage and frequency to control speed and torque.

ON / OFF SWITCH (57)

Disconnects the unit from the 230 Volts AC mains supply.

Caution: When the supply is switched off, capacitors in the control system will remain charged for a short time. Allow 60 seconds before handling the Control Card or Motor.

PROGRAMMING EXAMPLES

MASTER: 1 INPUT

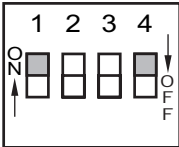

• **Configuration**

1. ON: 1 Input.
2. Depends on type of door.
3. Depends on type of door.
4. ON: Master.

• **Inputs**

- | | | |
|--------------|---------------|------------------------------------------------------------------------------------------------------------------------------|
| 1. (8) | Close. | Closes the doors with voltage between terminals 8 & 10. Open the doors when the voltage between terminals 8 & 10 is removed. |
| 2. (17...20) | Photocell. | Doors will reopen if the photocell beam is broken. |
| 3. (21-23) | Reopening. | Doors will not close if this signal is active. |
| 4. | Obstacle. | Door will open if an obstacle is detected by the motor ceasing to rotate. |
| 5. (25-23) | Slow Closing. | Closes regardless of the state of the photocell. |

• **Priorities**

- | | |
|--------------|---------------|
| 1. (21-23) | Reopening. |
| 2. | Obstacle. |
| 3. (25-23) | Slow Closing. |
| 4. (17...20) | Photocell. |
| 5. (8) | Close. |

SLAVE: 2 INPUTS

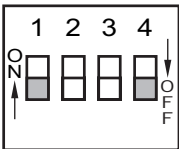

• **Configuration**

1. OFF: 2 Inputs.
2. Depends on type door.
3. Depends on type door.
4. OFF: Eslave.

• **Inputs**

- | | | |
|--------------|---------------|-----------------------------------------------------------------------------------------------------------|
| 1. (8) | Close. | Closes the doors with voltage between terminals 8 & 10. |
| 2. (12) | Open. | Open the doors with voltage between terminals 12 & 10. Priority to close. |
| 3. (17...20) | Photocell. | Does not re-open the doors when activated but provides signal to main controller via the Photocell relay. |
| 4. (21-23) | Reopening. | Doors will not close if this signal is active |
| 5. | Obstacle. | Doors will not re-open if an obstacle is detected by the motor ceasing to rotate. |
| 6. (25-23) | Slow Closing. | Closes regardless of the state of the photocell. |

• **Priorities**

- | | |
|------------|---------------|
| 1. (12) | Open. |
| 2. (21-23) | Reopening. |
| 3. (25-23) | Slow Closing. |
| 4. (8) | Close. |

POWER SUPPLY:

- AC voltage range: 230v +10%, -15%. AC/DC
- Frequency supply: 50...60 Hz.
- Minimum supply: 70 mA, 13W.
- Open door power: 0,6 A 80W.
- Nominal power: 0,93 A 140W.
- Maximum power: 1,38 A 190W.

INVERTER:

- Carrier frequency: 16 KHz.
- Frequency range: 0,5...100 Hz.
- Voltage range: 40...200 V AC III
- Maximum output current: 4 A
- Positional control: Quadrature encoder.

MOTOR:

- Asynchronous three phase: 6 poles.
- Voltage supply: 250 V.
- Power: 250 W.
- Thermic class: B-130°C.
- Nominal speed: 900 RPM.

INPUTS:

- Impedance: 20 K Ω .
- Voltage: 12...230 V AC / DC.

OUTPUTS:

- Contacts: Switched.
- R. contact: 50 mW.
- Switch time: 5 ms.
- Output current: Maximum: 5A
- Voltage: 250 V

PERFORMANCE:

- Open Speed: 200...1000 mm/s.
- Close speed: 150...600 mm/s.
- Maximum acceleration: 800...1500 mm/s.
- Safety force: 40...150 N adjustable.
- Maintenance torque (Opened Door): 80 N/ cm.

EMERGENCY SUPPLIER*

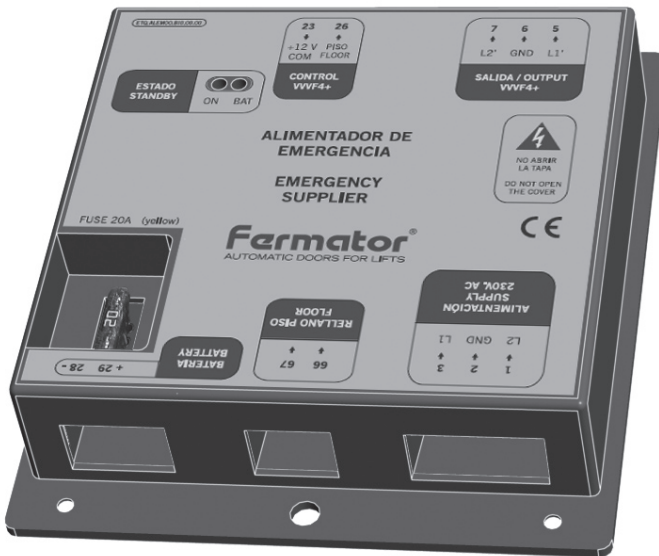

CHARACTERISTICS:

- 1 - Control by microprocessor.
- 2 - Verification of the battery charge level.
- 3 - Output power Until 1.5 A / 110 Volts .
- 4 - Complete control of the rescue process.

* NOTE: This system is only suitable for VVVF4+ circuits.

This equipment has a “bypass” relay that switches the supply for the VVVF control from the mains supply or from the internal converter if there is a mains power failure.

INSTALLATION

- 1 - It will be installed close to the VVVF, connected in the input side of the VVVF.
- 2 - The input supply to the VVVF will be connected to OUTPUT terminals 5/6/7 of the emergency supplier instead of being directly connected to the mains supply.
- 3 - The emergency supplier should be connected to a 230V AC mains supply on terminals 1/2/3 marked as SUPPLY 230V AC.
- 4 - A 12V rechargeable battery should be connected to terminals 28/29 marked BATTERY, special care should be given to the polarity (+29 and 28-) when connecting.
- 5 - To enable the doors to open correctly when on emergency supply a volt free contact should be provided to the VVVF box on terminals 66 and 67. This contact should be normally closed only at floor level and can be operational on normal and when on emergency supply. As this input is only operational during the mains power failure, no synchronization with the mains supply is needed.
- 6 - The contacts 23(+12V) and the 6 (GND) in the emergency supplier have to be connected to the output terminals 23(+12V COM) and 6(GND) respectively in the VVVF.
- 7 - The terminal 26 (FLOOR) of the emergency supplier has to be connected to the terminal 26 input in the VVVF4+ (FLOOR) to inform it about the mains supply status.

! If the polarity is reversed the 20 A fuse will blow and damage to the electronic board could occur. The battery should have a minimum capacity of 2 Ah.
Special care has to be taken with the cable and battery connector. The wire connecting the battery to the terminals 28/29 must be as short as possible and terminated properly, because the current can reach a peak level of 15A.

Once the system is installed, the ON led shows the system status:

- 1 - Always ON: means that the battery is not charged. The charge process of the battery can last about 48 hours, so after this time the Normal status should be achieved. If not, the battery is drained and not functioning.
- 2 - Blinking: means Normal status. The system is Ok and the battery is charged.
- 3 - Blinking every 15s: means that there is no 230V AC mains supply and the unit is waiting for the Floor signal to commence the “emergency open” process.

BATTERY CONTROL

As long as the emergency supplier is connected to the mains supply and with a battery connected, it charges the battery until 100% charge is achieved. When the charge level is lower than 70%, the charge process starts again.

If there is a mains power failure, the system waits for the Floor signal to open the door. This open cycle lasts for a fixed time after which the system starts a low power status waiting for the mains supply to be reinstated.

SCHEME

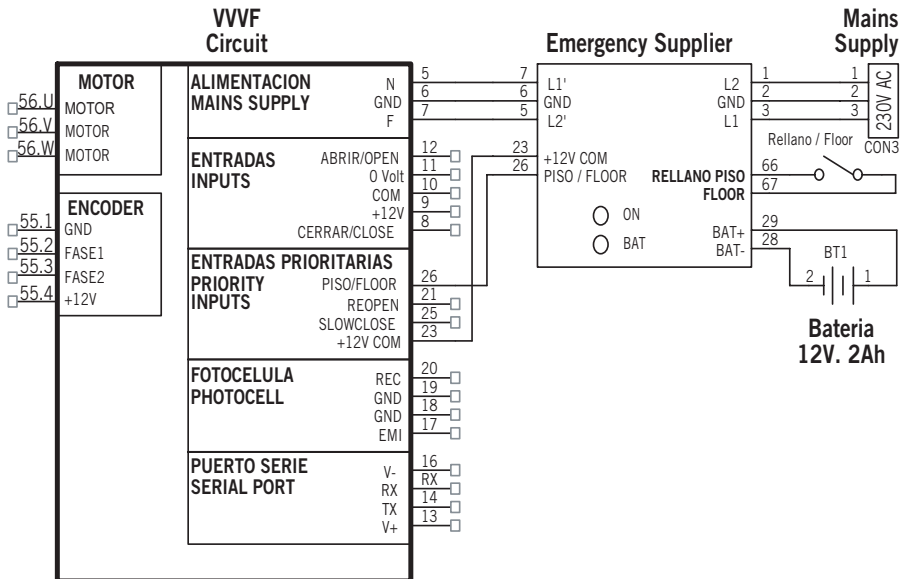

ATTENTION: Any type of modification not reflexed in this manual, before testing it should be notified to our Technical Department.

TECNOLAMA declines all responsibility in the case of damages produced in the operator and installation, if the instructions given have not been followed.

TECNOLAMA reserves the rights to modify the products specifications of this technical brochure without any previous advise.

DECLARATION OF CONFORMITY

*Tecnolama, S.A.
Ctra. Constantí Km. 3
43206 REUS (España)*

Herewith declares that the products mentioned below conform with the following E.U. council directives:



**E.U. council directive of electromagnetic compatibility and immunity
89/336-CEE, conform with Norms EN12015 and EN12016,
about lift doors:**

VVF-4⁺ Electronical Module
(EMI-431)

**E.U. council directive of electromagnetic compatibility and immunity
89/336-CEE, conform with Norms EN12015 and EN12016,
about lift doors:**

Manoeuvre system for lift doors 40/10 mechanical model
(EMI-370)

Tecnolama S.A., 2007

A handwritten signature in black ink, appearing to be 'Josep Vilà Gomis', written over a horizontal line.

Josep Vilà Gomis
Administrator

(tecnolama